

TAB754 Assembly

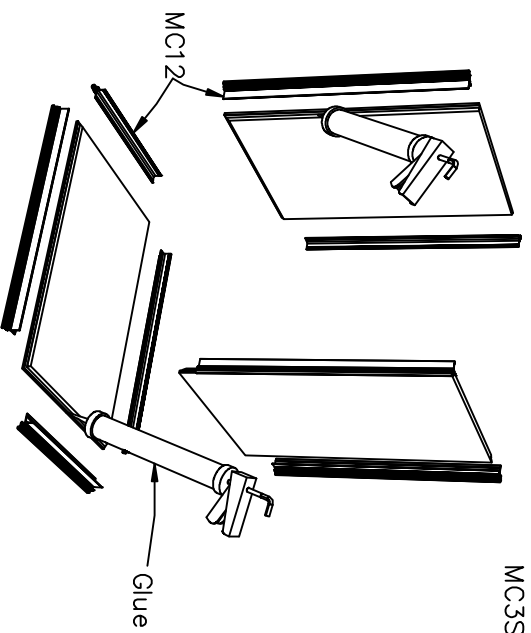

(1) Apply glue into grooves on the four grooves on the top and sides. Insert MC12 and tape to hold while glue sets.

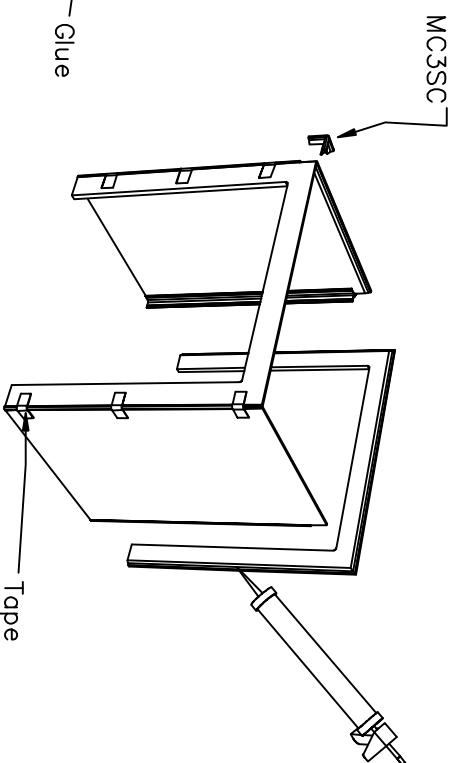

(2) Apply glue into grooves of the front and top of the assembled base. Use the MC3 Corners to keep checking the MC12 extrusion is correctly positioned as once the glue has set it cannot be moved.

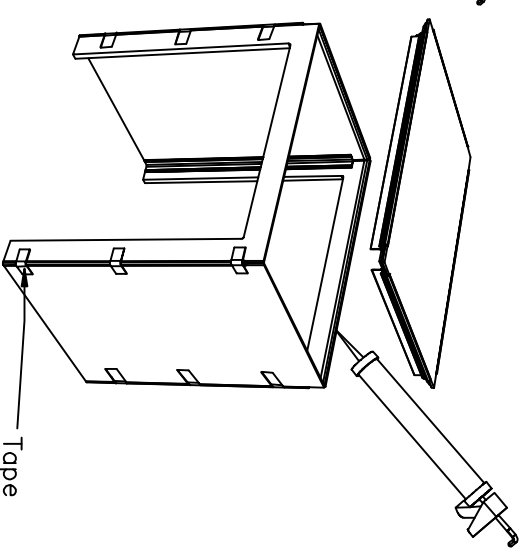

(3) Insert MC12 and progress the assembly. Tape to hold while glue sets.

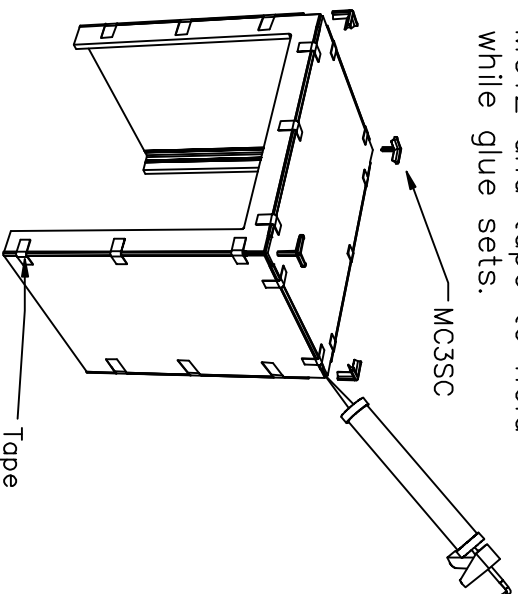

(4) Apply glue to corners and tape while glue sets.

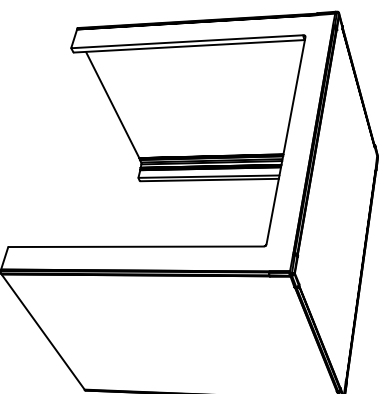

(5) Assembly completed.

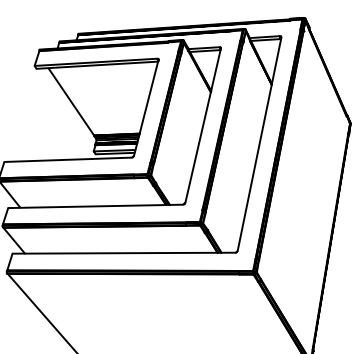

(6) Nest 3 difference size table together. Save space for storage. Easy packing and transporting.